

Danfoss Uses PLECS for the Development of a 1.2 MVA Dynamometer Converter

Introduction

Danfoss Drives A/S is known as a leading manufacturer of high performance variable frequency converters in the range of a hundred watts to a mega watt. The company produces thousands of drives annually with specialization in the fields of HVAC, water treatment, food & beverage and a



wide range of other industrial applications. Most of these drives are fed from a passive 6-diode rectifier as this allows the simplest design and lowest cost. Today there is a progressive shift towards the wider use of Active Front-End (AFE) converters, especially at high power where dynamic braking/energy recovery is needed, such as with large hoists and rolling mills.

Challenge

Confronted with the need to retrofit a 1 MW dynamometer bench with an AFE, Danfoss Drives' engineering team had an

unusual challenge on their hands: to build a one-off, 1.2 MW AFE in a short time, using off-the-shelf standard motor drives and have the system commissioned with minimal down-time of the test bench.

"Active Front Ends in the 1.2 MVA power range are not off-the-shelf products and need to be designed for their specific application", says Jens Godbersen, Research Engineer of Danfoss Drives', R&D Department, Graasten, Denmark. Some significant design challenges needed to be met – and to a tight schedule".

Even though the control and design of an AFE is well known and well described in the literature, some significant design challenges had to be overcome to satisfy the above constraints.

"In this project, we started with the design of an LCL filter interfacing the grid connection point", continues Godbersen, "Resonance issues, asymmetries, harmonics and faults had to be considered, along with different filter designs and comparisons of different methods of line synchronization. Clearly, fast and dependable simulation along with laboratory testing of the complete power electronic (PE) system would be fundamental to success".

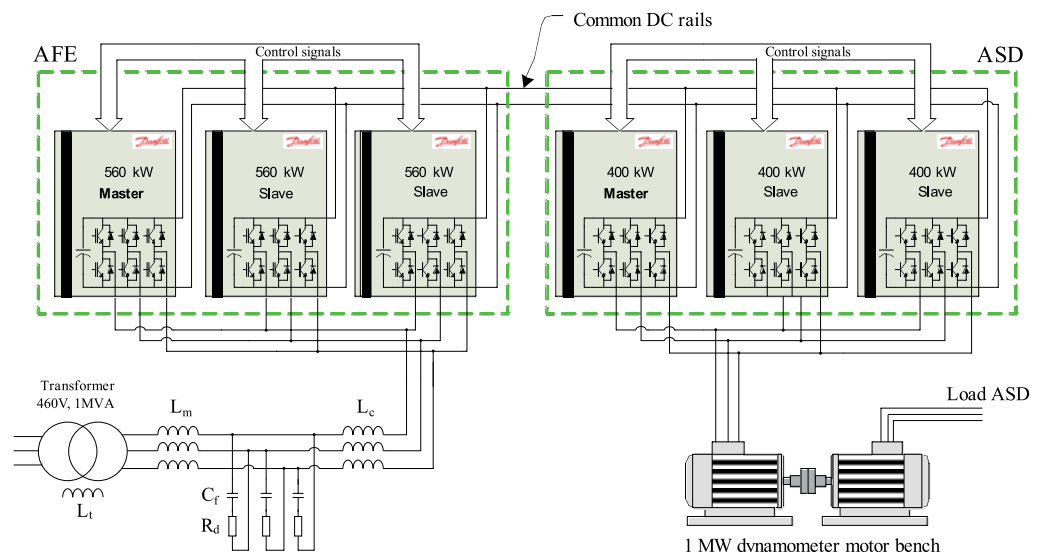

Figure 1: Complete dynamometer system based on standard drives in "hard-parallel" connection

Jens Godbersen:

„PLECS makes the design process very flexible and new ideas can be simulated with reliable results, before turning to the test bench and committing valuable resources.“



Photos: Danfoss

The project constraints led to the configuration of Fig. 1 in which standard 560 kW VLT® AutomationDrive frequency converters, having undergone only minor modifications, were “hard-parallel” connected, with one drive operating as a master AFE and the other two as slaves.

■ Simulation

A good simulation model of the system was fundamental to this project. By using PLECS® under Simulink®, it was possible to quickly determine the correct specifications for the LCL-filter. “Elimination of the usual design iterations was crucial to meeting the time constraints”, says Godbersen. “In this project, we were interested in optimizing the system, not the inverters and so PLECS’ ability to treat semiconductors as perfect switches was of great value: our simulations were fast and stable and we did not have to worry about integration step-widths or convergence issues”.

“User-friendliness is another great feature of PLECS: Building models via drag-and-drop from the rich library is very convenient“, adds Radu Lazar, Research Engineer of Danfoss’ R&D, “the intuitive graphical interface makes programming the circuit, very simple and since we already used

Simulink for our controllers, our whole team became ‘PE simulation experts’ overnight!”

■ Conclusion

Having used PLECS in a few projects now, Danfoss’ R&D department feels that PLECS is the natural choice for upcoming projects. Summarizes Godbersen: “PLECS makes the design process very flexible and new ideas can be simulated with reliable results, before turning to the test bench and committing valuable resources”.

